

INSTALLATION INSTRUCTIONS FOR ARMATURE (CATCH PLATE) KITS

DOOR HOLDER CATCH PLATE KITS	
Model Number	Type
CS 2595-5	Satin, short armature
CS 2595-6	Bronze, short armature
CS 2598-5	Satin, long armature
CS 2598-6	Bronze, long armature

MOUNTING ARMATURE ASSEMBLY

NOTE: Mount the armature assembly vertically (Figure 2) to obtain the correct alignment with the electromagnet.

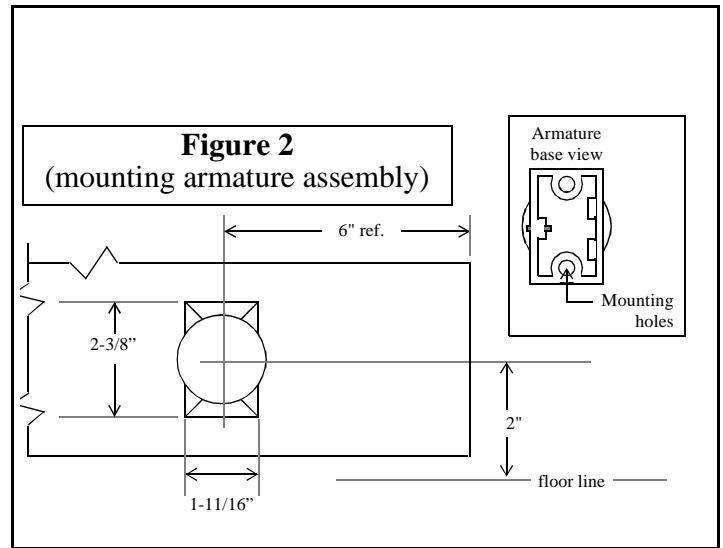
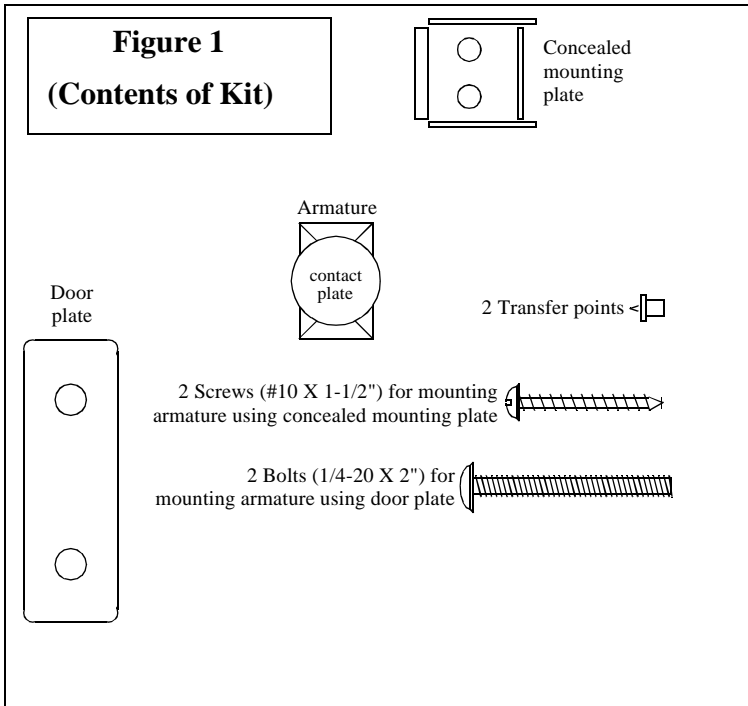

1. Using a 5/32" Allen wrench, turn the contact plate adjusting-screw (Figures 3 and 4) counterclockwise just enough to loosen the contact plate.
2. Place the transfer marking points in the armature mounting holes (Figure 2).
3. Holding the contact plate centered against the magnet, open the door and press against the transfer marking points on the armature base. This locates the two mounting holes in the door. Release the door, and remove the transfer marking points. Select a mounting method:

NOTE

There are two armature mounting options: one for hollow metal and composite doors, and the other for solid core wood doors.

- 4a. **Thru-bolt mounting** (Figure 3). Recommended for standard 1-3/4" hollow metal, hollow core, or composite type wood doors. Center punch the two marked points and drill 5/16" diameter through the door. The distance between their center points should equal 1-3/4". If a 2" door is used, two (2) 2-1/4" long 1/4-20 bolts are recommended. (Figure 3)

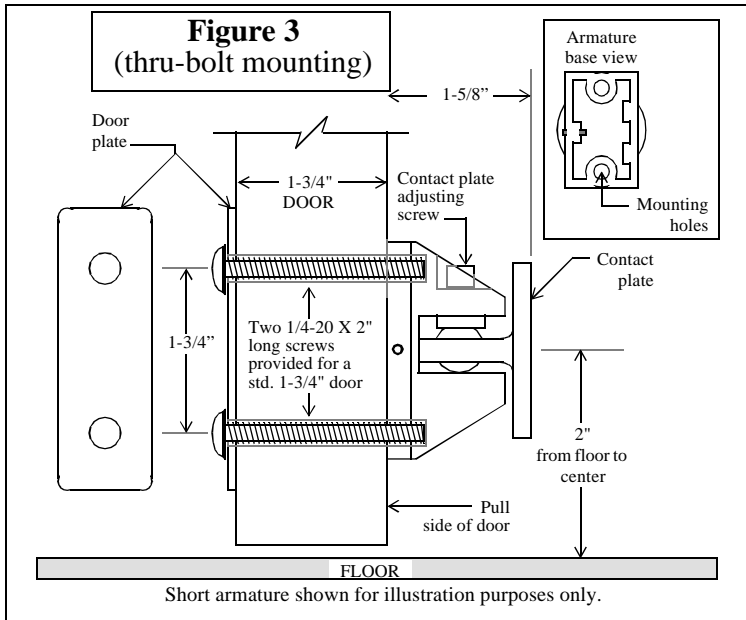

- 4b. **Surface concealed mounting** (Figure 4). Not recommended for hollow metal, hollow core or composite type wood doors. Center punch the two marked points and drill 1/8" diameter X 1-1/4" deep. The distance between their center points should equal 1/2". Install the concealed mounting plate using the two #10 X 1-1/2" screws provided. (Figure 4)

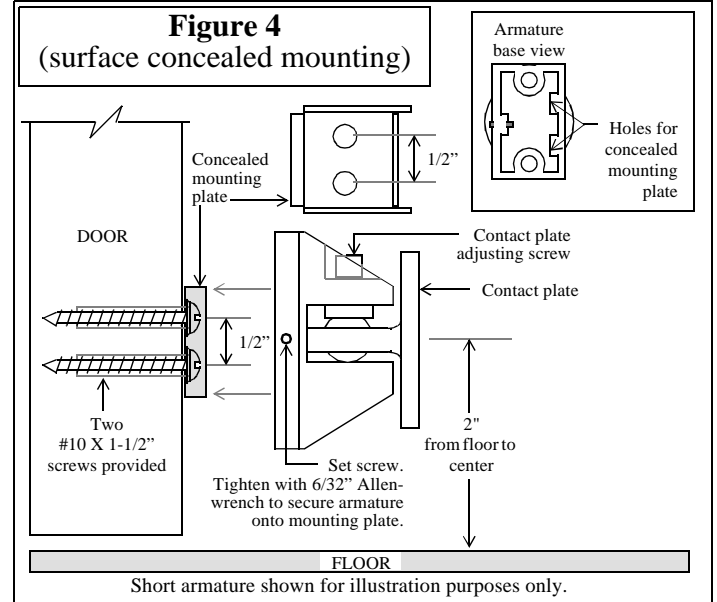

5. Secure the armature assembly to door, using Figure 3 or Figure 4 as a guide. The contact plate adjusting screw should face upward.
6. Align the contact plate against the electromagnet (it must be centered and lie flat against the magnet to ensure sufficient holding force. Tighten the contact plate adjusting screw. **Do not overtighten.** The plate must be firm but not overly rigid.
7. Check alignment and adjust if necessary.
8. Adjust the door closer to exert 3 pounds of force when the door is open and the armature and magnet are in contact.
9. Energize the electromagnet and open the door. If the door shuts, check the alignment of the contact plate and electromagnet. Also check that power is turned on to the unit and that the magnet is energized.