

E-278 Double Action Pull Station Installation Sheet

Operation

This E-278 Double Action Pull Station combines a dual action pull station with a single input analog addressable mini module mounted on the back of the unit. The pull station requires two actions to initiate an alarm. First, to access the alarm handle, raise the upper door marked LIFT THEN PULL HANDLE. Second, pull the alarm handle to initiate an alarm.

The device address is set using the two rotary switches located on the back of the mini module. One device address is required.

The mini module is configured for alarm latching operation. When the handle is pulled, an alarm signal is sent to the control panel and the alarm condition is latched at the pull station. The pull station must be manually reset prior to resetting the panel.

LEDs

The E-278 provides two status LEDs. The LEDs are visible from the back of the E-278.

Figure 1: LED location

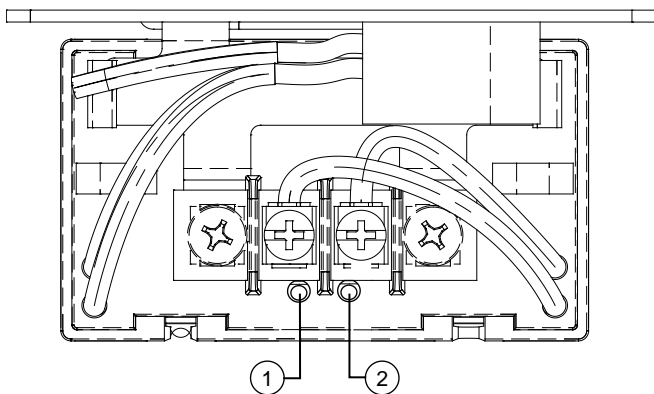

1. Red LED: Alarm/active 2. Green LED: Normal

Installation

WARNING: This pull station does not operate without electrical power. As fires frequently cause power interruption, discuss further safeguards with the local fire protection specialist.

Note: The pull station is shipped from the factory complete with a single input mini module attached. The module contains no user-serviceable parts and should not be disassembled.

To install the pull station:

- To meet the Americans with Disabilities Act (ADA), mount the electrical box 48 inches max. from the floor and attach the pull station using screws provided with the electrical box.
 - Set the required device address. For example, to set the device address for 21, set the TENS switch (marked 0 to 12) to 2 and the ONES switch (marked 0 to 9) to 1. See Figure 2.
- The devices can be addressed from 01 to 129. Panel addressing may vary.
- Verify that all field wiring is free of opens, shorts, and ground faults before connecting to the module terminals.
 - Make all wiring connections to the terminal block discussed in "Wiring" and shown in Figure 4.
 - Open the pull station by using a slotted screwdriver to twist the cover release screw counterclockwise while pulling the cover away from its back plate.
 - Mount the pull station in the electrical box.
 - If use of the glass rod is desired, pull the glass rod release lever and install the glass rod through the mounting bracket on the front of the pull station.
 - Set the toggle switch to the NORMAL position and snap the cover into its locked position.

Figure 2: Module address

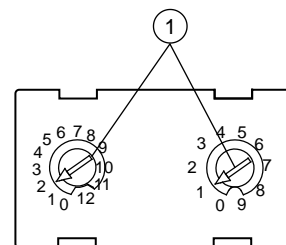

- Insert screwdriver here

Figure 3: Pull station installation

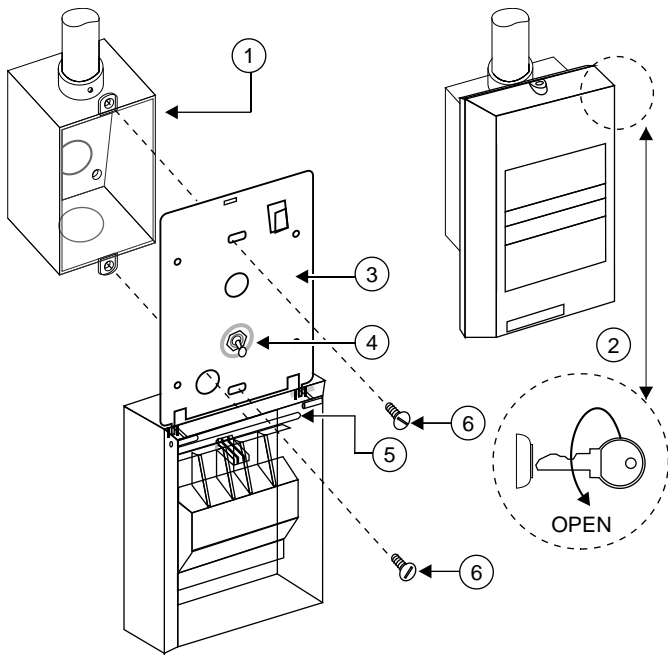

- | | |
|------------------------------|----------------------------|
| 1. Compatible electrical box | 4. Toggle switch |
| 2. Key-latch cover release | 5. Glass rod release lever |
| 3. Back plate | 6. Screw |

Wiring

Caution: For system supervision, do not loop the circuit wires around the terminals. Break the wire run at each terminal.

Wire in accordance with NFPA 72 and CAN/ULC-S524, Standard for the Installation of Fire Alarm Systems and in accordance with the local authorities having jurisdiction.

Be sure to observe the polarity of the wires as shown Figure 4.

For additional wiring information, refer to the documents listed on the control panel label.

All wiring is power-limited and supervised.

Regulatory information

Manufacturer	Edwards, A Division of UTC Fire & Security Americas Corporation, Inc. 8985 Town Center Parkway, Bradenton, FL 34202, USA
Year of manufacture	The first two digits of the product serial number (located on the product identification label) are the year of manufacture.
Environmental class	UL: Indoor dry
North American standards	UL 38, CAN/ULC-S528

Figure 4: Pull station wiring

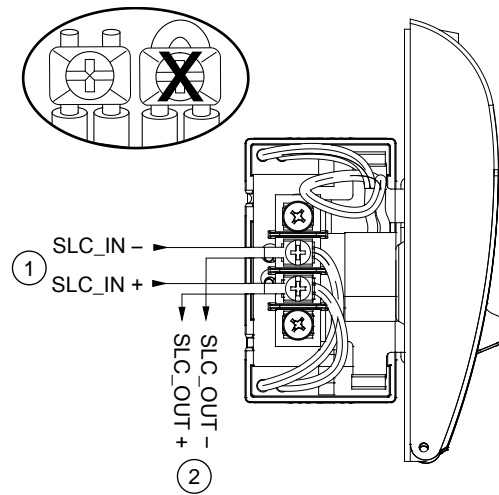

1. From previous device or control panel
2. To next device or EOL resistor

Specifications

Voltage	
IDC maximum	10 VDC at 350 μ A
Communication line maximum	20.6 V peak-to-peak
Current	
Standby	350 μ A
Activated	500 μ A
Wire size	12 to 18 AWG (0.75 to 2.5 mm ²)
Compatible electrical boxes	North American 2-1/2 in. (64 mm) deep single gang box Standard 4 in. square box 1-1/2 in. (38 mm) deep box with single gang mud ring
Special order surface mount boxes	27193-10 - Cream enamel finish 27193-11 - Red enamel finish
Replacement glass rods	USA, P/N 276-GLR (pkg. 20 rods) CAN, P/N 27165 (pkg. 12 rods)
Operating environment	
Temperature	32 to 120°F (0 to 49°C)
Relative humidity	0 to 93%, noncondensing
Storage temperature range	-4 to 140°F (-20 to 60°C)

Contact information

For contact information, see our Web site:
www.edwardssignaling.com.