

Installation Instructions for Catalog Series 94DV2(*)-N5 AdaptaBeacon® Signals

Description

The catalog number 94DV2(*)-N5 AdaptaBeacon signal is a UL listed strobe light. The signal is suitable for indoor or outdoor (weatherproof) installation and is constructed with Type 4X enclosure protection. It is suitable for installation in the Division 2 locations listed in Table 1.

These signals are designed for mounting on 1/2" (13 mm) NPT conduit.

Electrical Specifications

Rated Voltage 120V 50/60 Hz
Current 0.10 Amp

Installation

Install in accordance with the latest edition of the *National Electrical Code* and local regulations.



WARNING

To reduce the risks of igniting hazardous atmospheres and electric shock, ensure that power is disconnected before installing the signal.

1. Refer to Figure 1. Release the latch on the clamp ring and remove the ring holding the protective dome to the signal base. Lift the dome straight up off of the signal base. Remove the three screws holding the strobe tube support plate to the signal base, grasp the plate and carefully lift the support plate off of the signal base.
2. The 94DV2(*)-N5 signal must be conduit mounted.



WARNING

To prevent leakage and a potential shock hazard, when mounting outdoors the signal must be installed with the lens or dome facing directly up.

- a. Refer to Figure 1. The signal requires a 3/4" (19 mm) NPT conduit. Route the field wiring from the power source through the conduit and then through the conduit entrance hole in the signal base.
 - b. Install the signal base on the conduit.
3. Using wire nuts (not supplied), connect field wiring to signal wiring. Connect the green ground wire leads using wire nuts (not supplied).

4. Place the connected wires inside the signal base and reassemble the signal.
5. Turn on power and verify that the signal operates properly.

Maintenance



WARNING

To reduce the risks of igniting hazardous atmospheres and electric shock, disconnect power and allow five (5) minutes for stored energy to dissipate before disassembly. Do not connect power until unit is tightly assembled and secured.

Cleaning



CAUTION

To prevent damage to the lens, do not use abrasive materials or cleaners.

The signal's lens and dome should be periodically cleaned to maintain optimum light visibility. These items may be cleaned with a soft cloth or sponge using water or a mild detergent solution. Make sure the lens and dome are completely dry before replacing.

Strobe Tube Replacement

Refer to Table 2 for the required strobe tube.

1. Refer to Figure 1. Disconnect the power and wait five minutes. Lift the dome off of the signal base. Loosen the three screws in the keyhole slots in the base of the lens. Turn the lens clockwise and lift it straight up and off the strobe tube support plate. Next, remove the three screws holding the strobe tube support plate to the signal base. Grasp the socket (on the strobe tube support plate) and carefully lift the support plate off of the base.



CAUTION

To prevent damage to the strobe tube, handle the tube only by the base.

2. To remove the tube from the socket, grasp the base of the strobe tube and pull firmly, or carefully pry between the strobe tube base and the socket. Install the new strobe tube by aligning the key on the strobe tube base with the slot in the socket and then pressing the strobe tube base onto the socket. Reassemble the signal.
3. Turn on power and verify that the strobe operates.

*The letter in this position signifies the color of the supplied lens. A - amber, B - blue, C - clear, G - green, M - magenta or R - red.

Table 1. Division 2 Locations

| Class | Division | Group | Temp. Code |
|-------|----------|------------|-------------------|
| I | 2 | A, B, C, D | T3 (200°C, 392°F) |
| II | 2 | F, G | T6 (85°C, 185°F) |
| III | | | T6 (85°C, 185°F) |

Table 2. Replacement Parts

| Component | Catalog Number or Part Number |
|-------------------|-------------------------------|
| Xenon strobe tube | 92-ST |
| Dome | 94-DC |
| Lens | 93-L(*) |

*The letter in this position (A - amber, B - blue, C - clear, G - green, M - magenta or R - red) signifies the color of the lens; for example, a red lens for the 94DV2 series signal is 93-LR.

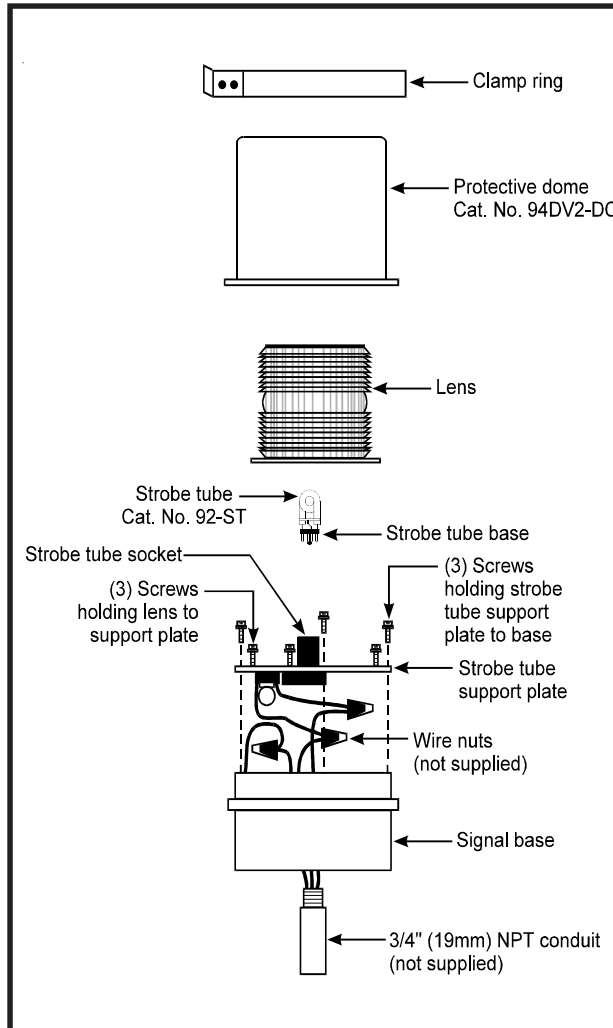

Figure 1. Mounting the 94DV2 Series Signal